



Product Datasheet

GEIGER-SOLIDline – Extension of the controls and motor heads range

I. Preliminary remarks:

The series **SOLIDline** has been introduced on the market on the occasion of the R + T exhibition 2009. It stands out for the highest processing quality it offers. The GEIGER motor series **SOLIDline** sets new standards for reliability, lifetime, power consumption and low noise emission.

It is universally used in many applications such as awnings, pergolas, screens, sunshades and rolling shutters.

The **SOLIDline** range grows again in 2011: four additional motor heads enable our customers to use the GEIGER motors in sun protection products where so far only limited use has been possible.

II. Customer benefits:

1. Keeping customers' requirements in mind

The new motor heads GEIGER were developed according to customers' specifications as an initial guide. They offer significant advantages:

- Meeting country-specific requirements of sunscreen manufacturers
- Using existing and commercially available fixation systems
- Supporting new product lines, e.g. ZIP systems
- Optimizing existing sun protection products, such as for example screens

2. High flexibility in the choice of motor heads and motor controls

Motor heads and motor controls play key role in determining whether a motorized drive can be used in a sunscreen product: the motor head must fit into the available space with the appropriate mounting options. At the same time, the motor control must take into account the special requirements of the device.

The GEIGER **SOLIDline** series offers in the future five different motor heads. We thus provide efficient conditions to operate all applications in which tubular motors are used.

Table of contents

I. Preliminary remarks:.....	1
II. Customer benefits:.....	1
III. Advantages of the SOLIDline series	3
IV. Product description.....	4

GEIGER-Touch –

The mechanical end stop with the 1-button technology

The GEIGER-1-button technology is a further development of the well-known mechanical end stop made by GEIGER.

Whereas previously TWO buttons were needed for the setting of the end positions, the SOLIDline motors only need ONE.

Ease of installation

Your advantages when setting the end positions:

- Standardized setting either with blinds, rolling shutters or awnings: the installation could not be easier.
- „Selection“ of the lower end position as long as the blind is positioned in the upper end position: most suitable for front-mounted rolling shutters: the end positions can be adjusted on site without scaffolding
- No time consuming adjustment, no risk of injury.
- Only one push-button: no risk of incorrect operation due to button confusion
- The limit switch range covers 35 revolutions: also suitable for very high blinds
- Factory setting of the upper limit position - Factory selection of the lower end position: no need to reopen the inspection opening on site

GEIGER offers now with the new **1-button technology**, a patented and proven worldwide system for rolling shutters and textile sun protection.

These five motor heads can be operated with 15 different motor controls which are specially set up to suit following sun protection systems:

- Rolling shutter systems
- Open style folding arm awnings
- Cassette awnings
- Winter garden awnings
- Awnings with double folding arms
- Facade awnings
- Screens
- Sunshades
- Pergola systems
- Sun sails

GEIGER works out the optimal combination of motor heads and motor controls – specially tailored to your needs.

3. Unity in Diversity

The diversity of the GEIGER motor heads gives our customers the possibility to achieve an optimum combination:

- Selection of the **OPTIMAL motor head** for an application
- Use of **ONE standard motor head** for many applications

The sunscreen manufacturer has now the opportunity to

- Optically upgrade his product with a space-saving motor head

AS WELL AS

- Reduce his stock by only using **ONE motor**.

The choice of a suitable motor control offers many advantages too:

- Standardization of motor types for open style folding arm awning and cassette awning (stock level reduction)

AS WELL AS

- Significant protection of the cloth, preventing that the edges get damaged.

III. Advantages of the SOLIDline series

Following features are common to all motor heads:

- **Plug-in cable**
The GEIGER plug can be removed or inserted at any time. This makes installation easier. In the event of transport damage, a damaged cable can easily be replaced without changing the whole device.
- **The fixation can be effected in two different ways:**
Each of the five motor heads can be mounted with a fixation system which has been especially built for this motor head. Moreover all five motor heads can be mounted with a standard star-shaped engine bearer. Here again, unity in diversity - The customer is free to select the fixation which is optimal for him.
- **Following torques are available:**
10 Nm, 20 Nm, 30 Nm and 40 Nm
- **Following motor controls are available:**

Mechanical end stop:	Electronic end stop:	Radio-controlled end stop :
Touch ¹⁾	Easy	VariousWireless
	SoftZero	SoftZeroWireless
	SoftPlus	SoftPlusWireless
	SoftPlus-DG	
	SoftPerfection	
	SoftPerfection-S	
	SoftReverse	
	SoftLock	
	Plug&Play	

¹⁾ not with **SOLIDline-ZN**

* Special motor controls on request

Specifications series GEIGER SOLIDline (GU45..)

	GU4510	GU4520	GU4530	GU4540
Voltage	230V~/50Hz	230V~/50Hz	230V~/50Hz	230V~/50Hz
Current	0,47 A	0,63 A	0,8 A	1,0 A
Cos Phi (cosφ)	>0,95	>0,95	>0,95	>0,95
Inrush current (factor)	x 1,2	x 1,2	x 1,2	x 1,2
Power	105 W	140 W	180 W	220 W
Torque	10 Nm	20 Nm	30 Nm	40 Nm
Speed of rotation²⁾	16 rpm	16 rpm	16 rpm	16 rpm
Protection type	IP 44	IP 44	IP 44	IP 44
Operating type	S2 4 min	S2 5 min	S2 4 min	S2 4 min
Weight	approx. 1,9 kg	approx. 2,2 kg	approx. 2,4 kg	approx. 2,7 kg

²⁾ SOLIDline motors are also available with 55, 99 and 134 rpm.

For more information, see our product datasheet „speed in the sun protection systems.“.





SOLIDline-ZN

IV. Product description

SOLIDline-ZN

This motor head has proven effective: it has been on the market since 2009 and is characterized by the following features:

- Extremely narrow motor head with 11 mm width
- This offers the opportunity to maximize the fabric width and reduce light slots on the sides of the cloth.
- User-friendly fixation system: the motor head is placed on the GEIGER engine bearer with clip system and locked. No tools necessary. A subsequent installation or removal is possible at any time by unlocking the retaining clip – easy operation and no risk of injury.
- Zinc motor head with 3 cable outlets offers high flexibility
- This motor head is available with all GEIGER electronic and radio controls, but not with the mechanical end stop GEIGER-Touch.

Application range: rolling shutter systems, open style folding arm awnings, cassette awnings, facade awnings and pergola systems.

Main target group: awnings

Dimensions tubular motor SOLIDline-ZN (GU45..A)

	GU4510A	GU4520A	GU4530A	GU4540A
Total length [l]	515,5 mm	545,5 mm	565,5 mm	585,5 mm
Length to tube drive [c]	498,5 mm	528,5 mm	548,5 mm	568,5 mm

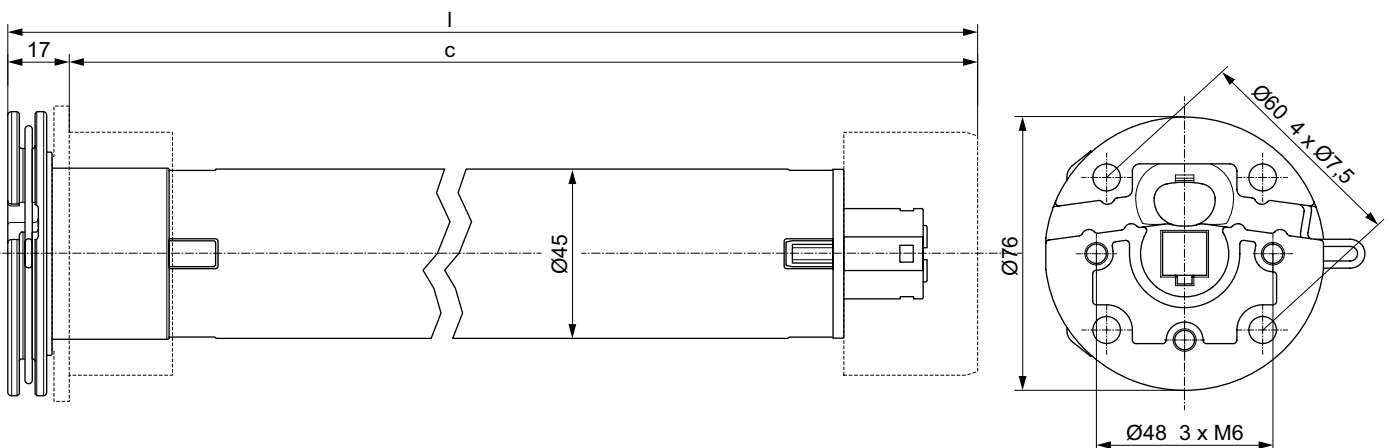

SOLIDline-KS

The SOLIDline-KS is based on the **SOLIDline-ZN**. Its advantages are similar to those of the **SOLIDline-ZN**.

Additional features:

- Optimized cable outlet opposite the setting button.
- By inserting two nuts, the motor can be screwed directly onto the console or the bracket (bolt circle 48).
- This motor head is also available with the mechanical limit stop GEIGER-Touch

Application range: rolling shutter systems, open style folding arm awnings, cassette awnings, facade awnings and pergola systems.

Main target group: open style folding arm awnings



SOLIDline-KS

Dimensions tubular motor SOLIDline-KS (GU45..B)				
	GU4510B	GU4520B	GU4530B	GU4540B
Total length [l]	516,5 mm	546,5 mm	566,5 mm	586,5 mm
Length to tube drive [c]	499,5 mm	529,5 mm	549,5 mm	569,5 mm

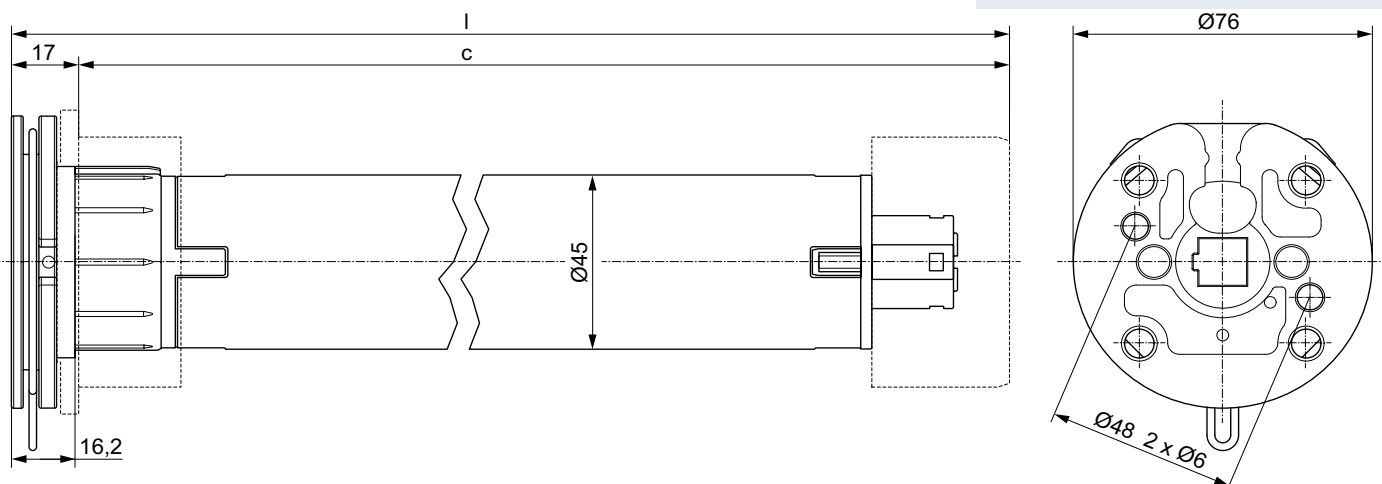



SOLIDline-COM

SOLIDline-COM

The **SOLIDline-COM** offers new options for product developers:

- Due to its extremely compact design, it fits into each bracket. This allows a downsizing of brackets and consoles which meets market trends and consumer requirements.
- Extremely small diameter (49 mm) suitable for use in ZIP-systems: the curtain can be rolled up over the head and the fabric width can be maximized because the cloth can also be wound on the motor head. In this case, the rotating lever can be removed and the motor can be mounted onto the bracket with the square receiver.
- In existing vertical awning systems, the curtain width can be maximized so that the lateral light strips are smaller than it has been the case up to now.
- A GEIGER specific fixation plate is available which can be locked/unlocked with a rotating lever on the motor head. The motor head can be easily mounted/demounted into the bracket without any risk of injury.
- This motor head is also available with the mechanical limit stop GEIGER-Touch

Application range: rolling shutter systems, open style folding arm awnings, cassette awnings, facade awnings and pergola systems.

Main target group: ZIP-systems, facade awnings and screens

Dimensions tubular motor SOLIDline-COM (GU45..C)

	GU4510C	GU4520C	GU4530C	GU4540C
Total length [l]	520,0 mm	550,0 mm	570,0 mm	590,0 mm
Length to tube drive [c]	499,5 mm	529,5 mm	549,5 mm	569,5 mm

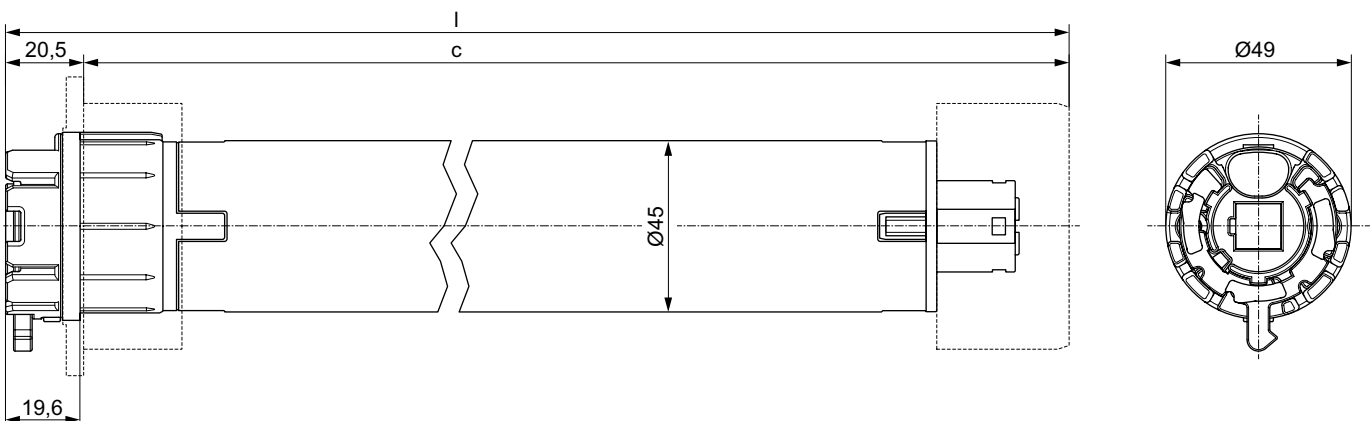

SOLIDline-SIC

The **SOLIDline-SIC** is most suited for fixing systems with cross pins. It can be universally used with all types of rolling shutter systems without having to give up proven fixation systems.

This motor head is also available with the mechanical limit stop GEIGER-Touch

Application range: rolling shutter systems, open style folding arm awnings, cassette awnings, facade awnings and pergola systems.

Main target group: rolling shutter systems: bloc baie, top mounted

Dimensions tubular motor SOLIDline-SIC (GU45..D)				
	GU4510D	GU4520D	GU4530D	GU4540D
Total length [l]	520,0 mm	550,0 mm	570,0 mm	590,0 mm
Length to tube drive [c]	499,5 mm	529,5 mm	549,5 mm	569,5 mm



SOLIDline-SIC

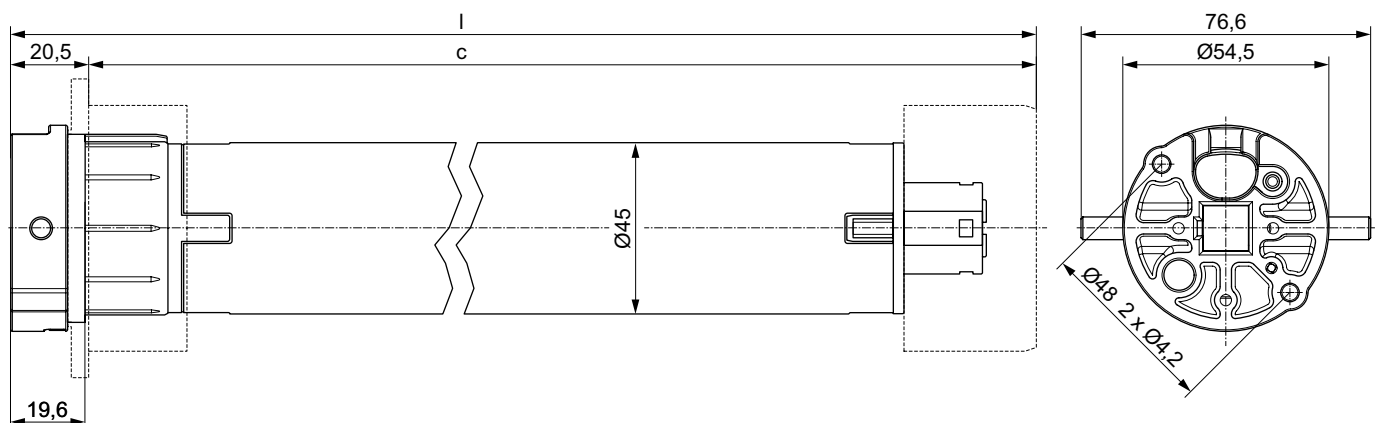



SOLIDline-SOC

SOLIDline-SOC

The **SOLIDline-SOC** is most suited for star-shaped fixation systems. It can be universally used with all types of rolling shutter systems without having to give up proven fixation systems.

This motor head is also available with the mechanical limit stop **GEIGER-Touch**

Application range: rolling shutter systems, open style folding arm awnings, cassette awnings, facade awnings and pergola systems.

Main target group: rolling shutter systems: bloc baie, top mounted

Dimensions tubular motor SOLIDline-SOC (GU45..E)

	GU4510E	GU4520E	GU4530E	GU4540E
Total length [l]	519,5 mm	549,5 mm	569,5 mm	589,5 mm
Length to tube drive [c]	498,0 mm	528,0 mm	548,0 mm	568,0 mm

