

Anti-lift device

DE Bedienungsanleitung

EN **Operating Instructions**

FR Manuel d'utilisation

ES Manual de instrucciones

IT Istruzioni per l'uso

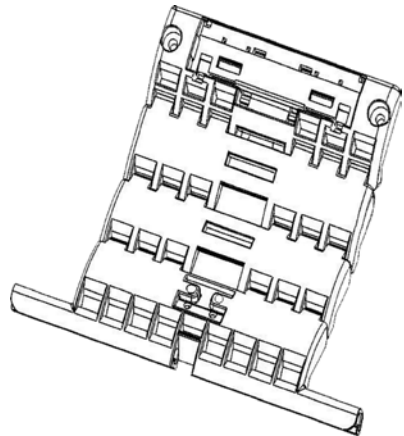

EN

1. General

Dear customer,

By purchasing a GEIGER anti-lift device you have decided on a quality product from GEIGER. Thank you very much to your decision and the confidence placed in us.

Please retain this information for future reference.

Before you put the anti-lift device into operation please observe the following safety information. It serves for the prevention of danger and for the avoidance of personal injury and damage to property.

2. Intended Use

The anti-lift devices are designed exclusively for the protection of rolling shutters. If they are used for other applications and/or modifications are performed to the anti-lift device, which have not been discussed with GEIGER Antriebstechnik, then the manufacturer is **not** liable for personal injury and/or damage to property and for consequential damage.

3. Installation instructions

During the assembly with screws, make sure that the tubular motor housing does not come into contact with the screws.

Please handle with care. The anti-lift device is suitable for max. 60 mm octagonal tubes.

Recommended screws: 3,5 x6, 5 DIN 7981 F H

4. Assembly instructions

A distance **X** of min. 30 mm and max. 80 mm must be respected between two anti-lift devices.

The distance **Y** should be at least 400 mm and not exceed 600 mm.

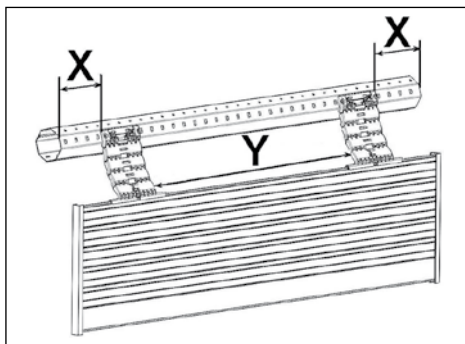

EN

Using a clip system:

The anti-lift devices can be connected without screws when the octagonal tube shows a rectangular hole (5,5 mm x 8 mm).

The bars located below the device must be fitted into the hole **S**.

In order to connect the anti-lift device with the octagonal tube, slide the upper bar in the direction **R**.

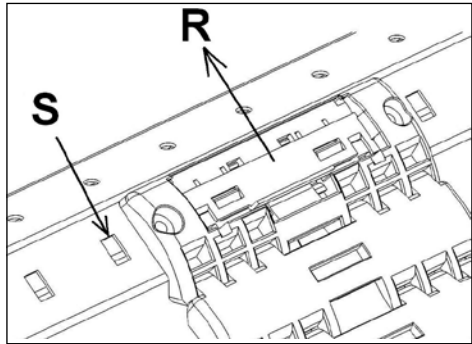

The anti-lift device can be removed by pressing down the retaining lug and then repositioned.

The anti-lift effect works only if the individual elements support one another (see picture) and when the first rolling shutter profile is pressed down into the guide rail.

Positioning into the guide rail of the first rolling shutter profile: not less than 1 / 3 of the profile height **A** and not more than 2 / 3 of the profile height **B**.

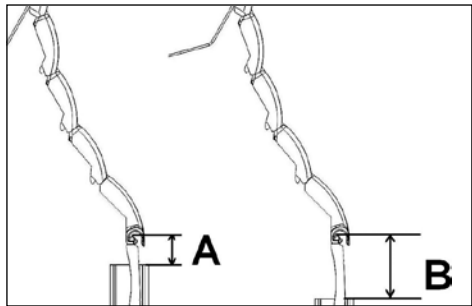

5. Technical Data

Mini-Profil Article Nr.	Maxi-Profil Article Nr.	Description	Required quantity for one shutter
M45F950	M45F956	2-element, clip system	It is recommended to fix one anti-lift device at intervals of 40/60 cm or for each 5 Nm engine power. Max. 9 kg per device.
M45F951	M45F957	3-element, clip system	
M45F953	M45F959	2-element, screw system	
M45F954	M45F960	3-element, screw system	

Subject to technical modifications

6. Notes on waste disposal

In the interest of environmental protection, please contact your local government's recycling or solid waste management department to learn more about the services it provides.



Please recycle the packaging materials.

EN

**For technical questions, please call our service team at: +49 (0) 7142 938-300.
They will be happy to assist you.**



Gerhard Geiger GmbH & Co. KG
Schleifmühle 6
D-74321 Bietigheim-Bissingen
Telephone: +49 (0) 7142 938-0
Telefax: +49 (0) 7142 938-230
www.geiger-antriebstechnik.de
info@geiger-antriebstechnik.de